

Item	Qty	Description
30	1	38" S44 Vertical Extrusion w/SEG
31a/31b	1/1	41.2385" Z45 Curved Horizontal Extrusion w/SEG
32	1	38" S44 Vertical Extrusion
33	2	16.35" Z45 Horizontal Extrusion
34	2	41.2385" Z45 Curved Horizontal Extrusion

**Steps:**

- 1) Attach curved panels [1,2] together.
- 2) Attach horizontals [31a,31b] between panels and vertical [30] as shown.
- 3) Attach horizontals [33] between verticals [30 & 32], inserting infill as shown.
- 4) Attach horizontals [34] between panels and vertical [32] as shown.
- 5) Place internal shelf on shelf supports.
- 6) Set counter tops on top of assembled base.
- 7) Apply graphic to SEG groove as shown on general information pages.

Item	Description
1	5.75"r x 42"h Half Curve Panel
2	5.75"r x 42"h Half Curve Panel

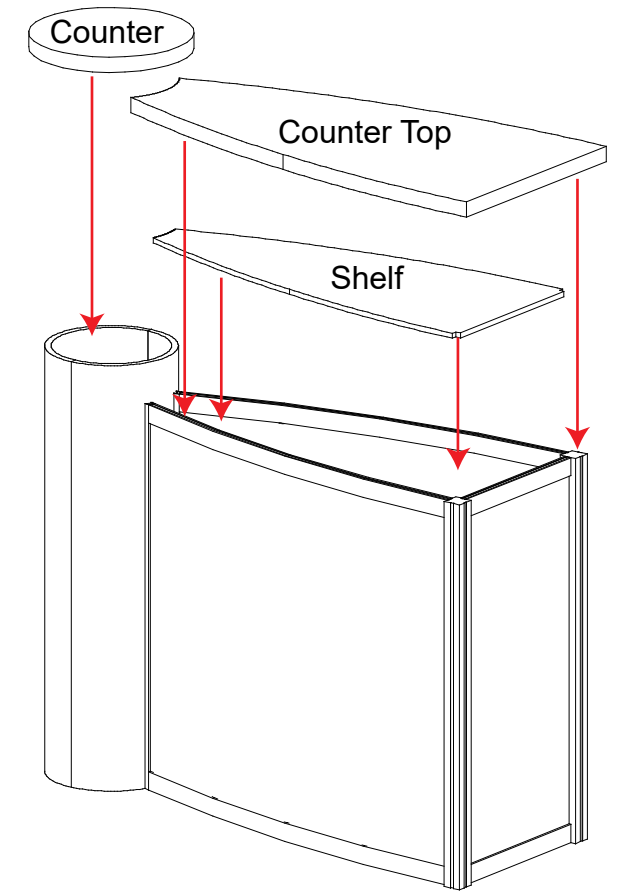
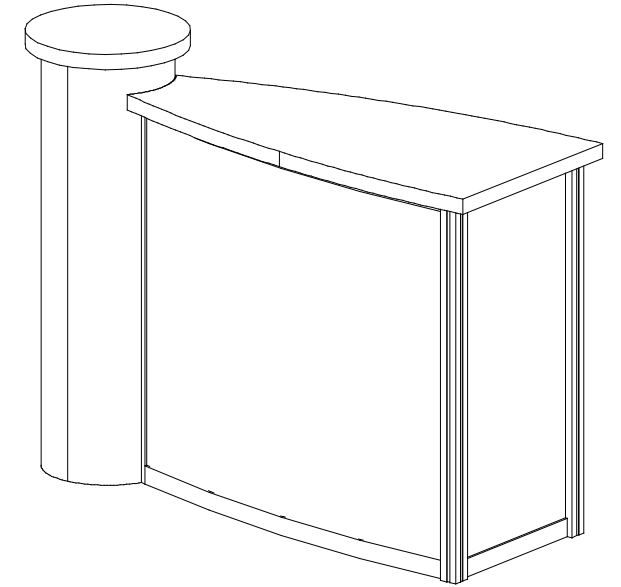
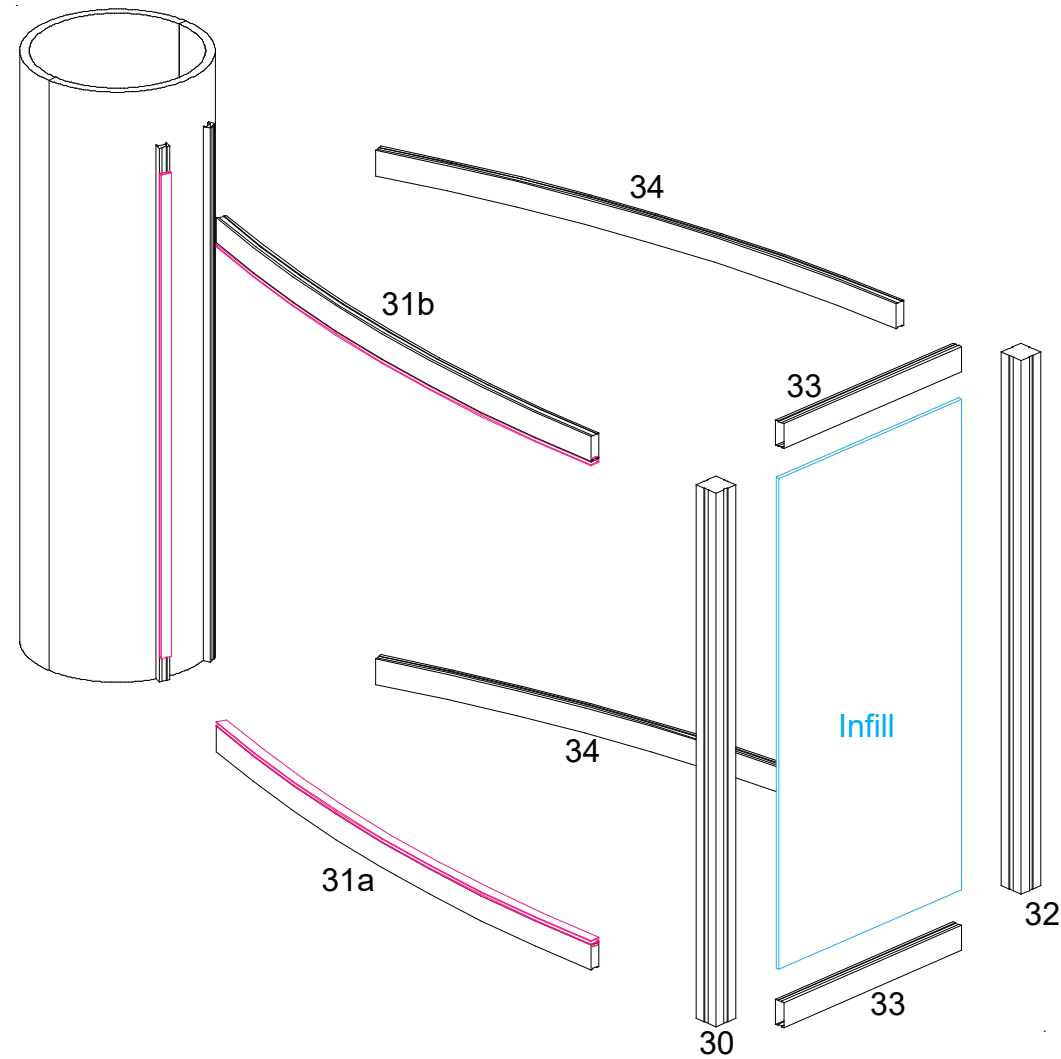
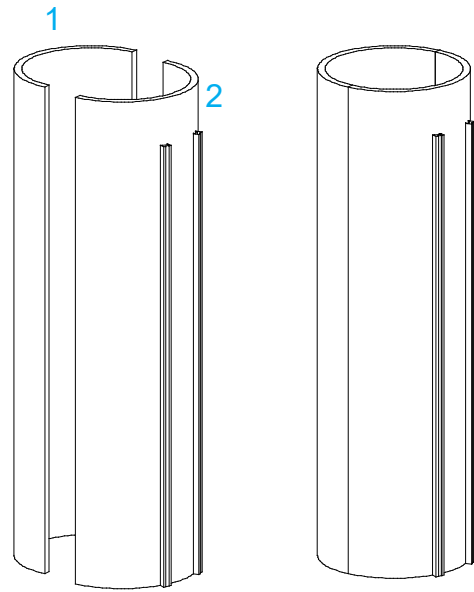

# SETUP INSTRUCTIONS

## General Setup Instructions

- Read entire setup instruction manual prior to unpacking parts and pieces.
- The setup instructions are created specifically for this configuration.
- Setup instructions are laid out sequentially in steps, including exploded views with detailed explanation for assembly.

## Cleaning & Packing

- For Cleaning Metal, Plex, & Laminate Parts: Use a **MILD NON-ABRASIVE** cleanser and soft cloth/paper towel to clean all surfaces.
- Keep exhibit components away from heat and prolonged sun exposure. **Heat and UV exposure will warp and fade components.**
- Retain all provided Packing Materials. All provided packing materials are for ease of repacking & component protection.

## Disassembly

- For loss prevention, tighten all set screws and locks during disassembly.

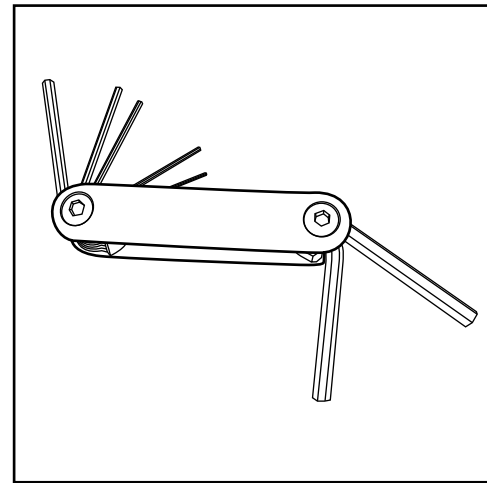

Hex Tool - Essential for Assembly

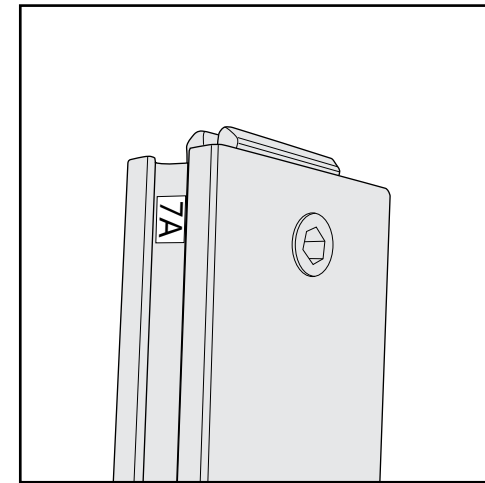

Part Identification - Numbering

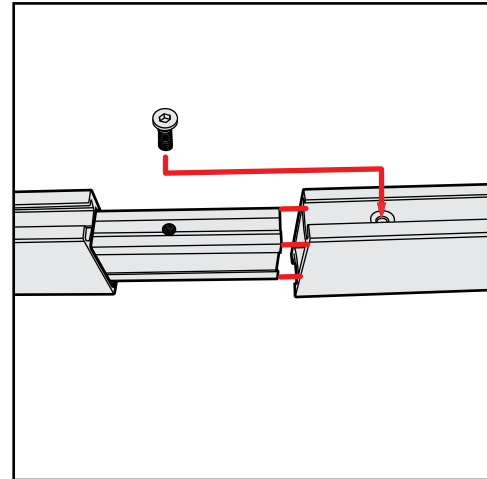

Spline Connection

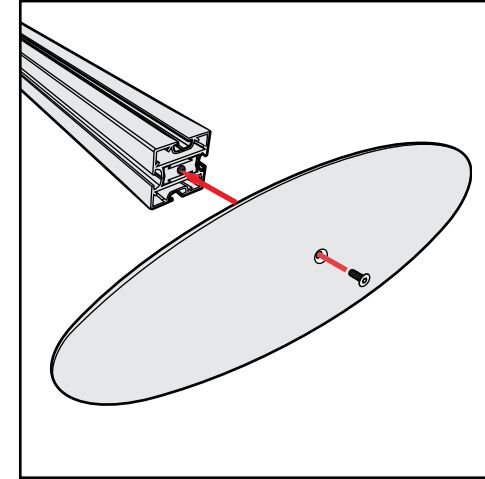

Base Plate & Extrusion Connection

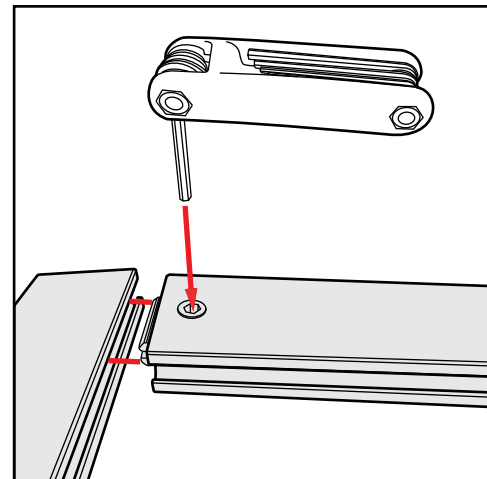

Extrusion & Lock Connection

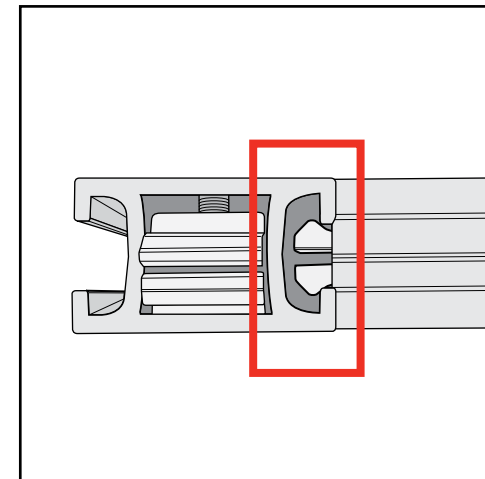

Engaged Lock



**WARNING**



DO NOT USE POWER TOOLS

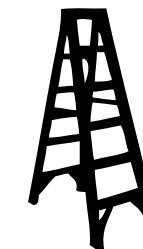

LADDERS OR LIFTS  
MAY BE REQUIRED



ALL CONNECTIONS MUST  
BE TIGHTLY SECURED